

TABLE OF CONTENTS

PREFACE	4	FAQ ABOUT TARGET LASERTRACK	10
AREA OF APPLICATION OF THE TARGET LASERTRACK	5	INSTALLATION OF THE LT425 CONTROL CIRCUIT BOARD AND THE LT420 BASIC TRANSPONDER	11
CONTENTS OF THE PACKAGE AND OPTIONAL ACCESSORIES	5	TECHNICAL SPECIFICATIONS	13
IMPORTANT INFORMATION	6	CONDITIONS OF GUARANTEE	14
INSTALLATION	6	CONNECTION DIAGRAM	88
TRANSPONDER ALIGNMENT	7		
CALCULATION TABLE FOR THE INSTALLATION OF THE TRANSPONDER	8		
TESTING THE OPERATION	9		
IMPORTANT INFORMATION FOR ALL USERS	9		

PREFACE

You have just purchased a TARGET LaserTrack and are now the owner of a very advanced Class 1 laser remote control system which can be used for various actions. The system is unique because it allows you to open your automated gate, garage door or turn on or off the outdoor lighting fully automatically, i.e. without pressing a button, at a distance equal to that of radiographic remote control systems. The unique code of your vehicle is automatically recognized by the basic transponder(s) as soon as you are within range through the patented "trigger and reply" tech-

nology. The Class 1 laser technology used is safe, reliable and is more user-friendly than conventional remote control systems.

The automotive industry has also discovered the advantages of laser technology. Nissan already introduced an "adaptive cruise control system" which automatically determines the distance to the cars in front of it and which adjusts the speed accordingly if required. Laser technology is also widely applied for distance measuring systems that can be mounted in the vehicles after these have left the factory.

We believe our system can increase the comfort of driving and wish you many happy years using your TARGET LaserTrack.

We recommend you read this manual thoroughly in order to get fully acquainted with the system.

Target Automotive BV

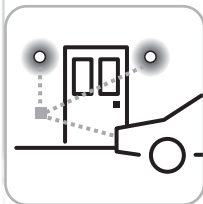
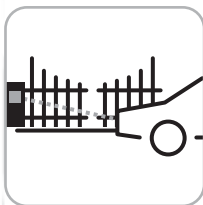
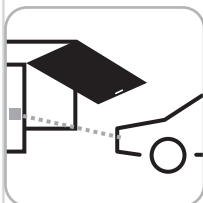
**AREA OF APPLICATION OF
THE TARGET LASERTRACK****1. Exterior lighting****2. Access control****3. Garage doors****THE TARGET LASERTRACK IS
DELIVERED IN 3 PACKAGES:****LT 400 Vehicle System**

- 1 LT 400 car transponder (refer also to the accessories)
- 1 LED
- 1 Piezo signal device
- 1 Water leveller
- All required connection and fastening material

LT 430 House System

- 1 LT420 basic transponder
- 1 Control circuit board LT425
- 1 Water leveller
- All required connection and fastening material

LT 450 Complete System

- 1 LT 400 car transponder
- 1 LT420 basic transponder
- 1 LT425 control circuit board
- 1 Piezo signal device
- 1 LED
- 1 Water leveller
- All required connection and fastening material

ACCESSORIES (OPTIONAL)

A special transponder for motorcycles is available. For motorcycles order the TARGET LT400-M. The control elements of this set are completely waterproof and weatherproof. This system also has a special optical signalling system that is always visible to the motorcyclist.

IMPORTANT INFORMATION

Nearly all laser systems using infrared light emit their information on a frequency of 904 nanometre (this is the wave length which emits infrared laser light). This is also true for the LaserTrack. This wave length has become the worldwide standard. Even the police laser guns emit speed measurements on this wave length. TARGET LaserTrack is the only system that has intelligent electronic technology that can recognize the signals of laser guns and other laser systems that use the same wave length. After recognizing an infrared signal that is not its own, TARGET LaserTrack temporarily shuts itself off to prevent failures and, for example, to allow a laser speed measurement to take place. You are informed of this through a visual and audio signal.

INSTALLATION

Follow the instructions below to the letter to ensure that the system performs optimally.

MOUNTING AND CONNECTING THE LT400 CAR TRANSPONDER

1. Mount the transponder preferably in the middle at the front of the vehicle (preferably very near to the number plate). The transponder may also be mounted behind the grill. The free passage opening should be larger when the distance from the transponder to the opening is greater.***
Refer to the calculation table on page 8.
2. Mount the transponder using the tee bolt and mounting bracket included in the package.
(Refer to Transponder Alignment on page 7.)
3. Ensure the transponder is aligned correctly
(refer to Transponder Alignment on page 7).
4. Lead the transponder cable through the engine compartment. Use the cable guides already present when possible. Do not pull the cable too tightly and do not kink the cable. Lead the cable through the existing grommet to the interior. Connect as indicated in the diagram on page 88.

CABLE CONNECTION:
LT400
Connect to:

1. Red Switched 12 V from the vehicle (+15). This is the cable with 12 V as soon as the vehicle is started. Mount a fuse for this connection. A switch can be added to this connection if required.
2. Black Earth. Connect this cable to a good earth source. Preferably a section of the chassis of the vehicle.
3. Yellow Connect with the red cable of the Piezo signal device. Connect the black cable of the signal device to earth.
4. White Connect with the red cable of the LED. Connect the black cable of the LED to earth.
5. Green Do not use. Insulate the cable using insulating tape.
6. Blue Do not use. Insulate the cable using insulating tape.

TRANSPONDER ALIGNMENT

The correct alignment of the transponder is very important. It should be aligned correctly **vertically** and **horizontally**.

Vertical alignment: Upwards / Downwards. The transponder can be adjusted upwards or downwards by turning the angle iron included in the package. This is the vertical alignment. Make sure the vehicle is level. Use the water leveller included in the package to adjust the vertical position. Place the water leveller just above the transponder and fasten the transponder in the correct position.

Horizontal alignment: Left / Right. The transponder can be turned around itself using the tee bolt. This is the horizontal alignment. The transponder should be placed at a right angle of the vehicle.

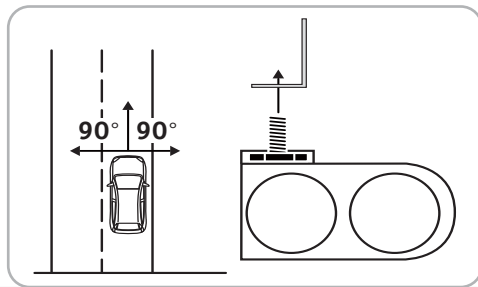

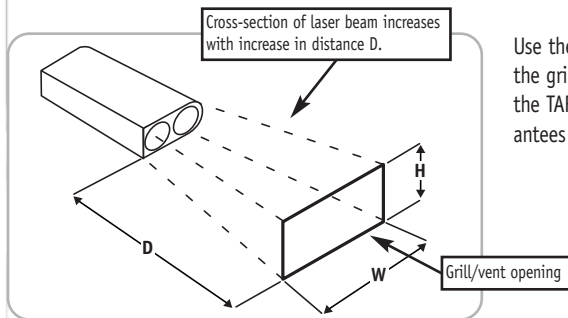
**CALCULATION TABLE FOR THE
INSTALLATION OF THE TRANSPONDER**

Use the table below when mounting the transponder in the grill or behind a vent hole of the vehicle. Mounting the TARGET LaserTrack using the parameters below guarantees maximum performance.

Measurements are in millimetres

Minimum height	H	6	8	9	10	11	13	14	15	16	18	19	20	21
Minimum width	W	16	18	21	23	26	28	31	33	36	38	41	43	46
Maximum depth	D	0	12	24	36	48	60	72	84	96	108	120	132	144

Minimum height	H	23	24	25	26	28	29	30	32	33	34	35	37	38
Minimum width	W	48	51	53	56	58	61	63	66	68	71	74	76	79
Maximum depth	D	156	168	180	192	204	216	228	240	252	264	276	288	300

TESTING THE OPERATION

The correct operation of the system can be tested after the TARGET LT400 has been installed according to the instructions.

1. Switch the system on by starting the vehicle (if the switch has been added then it must be set to ON).

Result: The system emits a short audio signal and the LED is switched on for 2 seconds. The LT400 will be in test mode for 10 seconds.

2. Test the operation of the laser receiver using an infrared remote control device (for audio or video equipment). Hold the remote control device in front of the transponder lens (at a distance of approximately 10 cm) and at the same time press a button of the remote control device.

Result: The system emits a warning signal and the LED is switched on.

3. Stop pressing the button of the remote control device when you are satisfied that the system is functioning correctly.

Result: After the last received signal the LED will be switched on for 10 seconds. After the 10 seconds have elapsed the system will emit two short audio signals. The LT400 is now in the stand-by mode.

IMPORTANT INFORMATION FOR ALL USERS

- Check frequently whether the lens of the transponder is dirty. The effect of dust and grit on the functioning of the system is very limited. Objects that cover the lens completely, such as leaves or insects, should be removed at once.
- Check frequently whether the housing and the lens of the transponder show signs of damage. Contact your dealer if the lens is damaged.
- A dealer should check the tuning of the transponder periodically (for example, when the vehicle is serviced).

FAQ ABOUT TARGET LASERTRACK

- 1. Can other Target LaserTrack users gain access to my grounds or garage?**

No, Target LaserTrack has more than 4.5 thousand million unique codes. Only vehicles for which the code has been programmed in the basic transponder can gain access.

- 2. Does the Target LaserTrack laser beam damage the eye?**

No, the Target LaserTrack is a Class 1 laser and is, therefore, completely safe.

- 3. Can I control other systems or equipment than those mentioned in the manual using the Target LaserTrack?**

Yes, in principle all electrical systems can be switched on and off remotely using the Target LaserTrack. We recommend contacting the dealer for the system before applying the Target LaserTrack.

- 4. Does the Target LaserTrack meet all the legal requirements and can I legally use the system anywhere?**

Yes, the Target LaserTrack meets the highest European standards for automotive accessories. Although interference with other equipment such as laser guns cannot be ruled out, the system may be used everywhere for the purpose it was developed. The system may not be used for other purposes than that for which it was developed by the manufacturer.

- 5. Is the Target LaserTrack influenced by police laser guns or other infrared laser systems?**

Yes, every laser gun or other laser system that emits on a frequency of 904 nanometre is recognized by the Target LaserTrack as an external source of interference. The Target LaserTrack shall always switch itself off after a few seconds to prevent mutual interference.

INSTALLATION OF THE LT425 CONTROL CIRCUIT BOARD AND THE LT420 BASIC TRANSPONDER

MOUNTING THE LT420 BASIC TRANSPONDER

1. The LT420 basic transponder is mounted in the same way as the LT400 car transponder. Ensure that the transponder is mounted at a location where it can detect the arriving vehicle. Avoid mounting it behind bushes or other obstacles.
2. Mount the LT420 at the same height or as near to it as possible as the LT400 on your vehicle. This is especially important to guarantee the communication between the vehicle transponder and basic transponder at a short distance.
3. Make sure the cable is long enough to reach the location where the control circuit board is mounted.
4. Ensure that the cable cannot be pinched. Especially when the system is used to open and close gates.
5. Connect the plug of the LT420 to the control circuit board.

Two LT420 transponders can be connected to the control circuit board (depending on the actual circumstances).

CONNECTING THE LT 425 CONTROL CIRCUIT BOARD TO THE GATE OR GARAGE DOOR

The control circuit board is connected to the garage door or gate differently depending on the brand and type of door or gate.

Refer to the garage or gate system dealer for instructions for the connection of the system to your gate or door.

The switching off can be delayed by 5 to 120 seconds when the potentiometer is connected to the control circuit board. Turn the potentiometer in the direction of the arrow to increase the delay.

The control circuit board should be placed in a separate waterproof cabinet if it cannot be placed inside the gate or garage door switch box.

**PROGRAMMING THE
TARGET LASERTRACK**

1. Park your vehicle at a few meters distance and in line with the basic transponder. Make sure that the LT400 is in stand-by mode.
2. Press the **BUTTON-1** or **BUTTON-2** button (depending on the group it is connected to) on the control circuit board for 2 seconds.

Result: The corresponding LED blinks. LED 10 shall blink for 10 seconds and it will subsequently start flashing when the code from the LT400 is received. The code of the vehicle is saved in the memory.

OR

Result: The corresponding led blinks repeatedly for 30 seconds after which it returns to the usual flashing pattern. This means that the code of the vehicle has not been received. Check the position of the vehicle and the basic transponder and repeat the procedure from step 2 onwards.

A maximum of 50 vehicles can be programmed into the system in the above manner.

Program the second transponder in manner described above if you have connected two LT420 transponders to a single control circuit board.

Important: The car transponder concerned has to be reset after programming the LT400 car transponder. The LT400 switches off after a programming cycle to prevent the gate or garage door to be opened immediately.

**DELETING VEHICLES FROM
THE BASIC SYSTEM MEMORY**

All the codes saved in the memory of the connected transponder shall be deleted if you press **BUTTON-1** or **BUTTON-2** for more than 5 seconds. The LED shall blink 5 times to confirm it.

The vehicles that should have access should be programmed into the memory again.

TECHNICAL SPECIFICATIONS**LT400**

Type of emitter	: Indium Gallium Arsenide laser diode, Class 1
Type of receiver	: Infrared photodiode with optical and electronic amplifier
Wave length	: 904 nanometre
Unique codes	: > 4.500.000.000
Measurements in millimetres	: Transponder 75 x 39 x 22 (l x w x h)
Transponder housing	: Aluminium, waterproof
Supply voltage	: 13.8 volt DC (nominal)
Acoustic signalling	: 87 dBA.
Period of transmission after trigger	: Maximum 8 seconds, reset time is 60 seconds
Power consumption	: 500 mA max.

LT420

Type of receiver	: Infrared photodiode with optical and electronic amplifier
Wave length	: 904 nanometre
Maximum number of memory slots LT400	: 50
Measurements in millimetres	: Transponder 75 x 39 x 22 (l x w x h)
Transponder housing	: Aluminium, waterproof
Supply voltage	: through the LT425

LT425

Supply voltage	: AC / DC 20 – 27 V (max.)
Maximum relay load	: 3 A 12 – 250 V AC / DC
Switching delay	: min. 5 – max. 120 seconds Variable through a potentiometre
Maximum number of connected LT420 transponders	: 2
Power consumption	: 300 mA max. (with 2 connected LT420 transponders)

Conditions of Guarantee

1. The manufacturer guarantees the reliability of the system. The guarantee is valid for a term of 12 months for what concerns manufacturing and/or material failure and the following (excluding all other):
 - If and when the system is used for the purpose for which it was designed and is mounted and used in the correct manner and under circumstances that can be deemed to be normal, and all this according to the regulations and/or instructions of the manufacturer.
 - If and when the buyer has met all his responsibilities and the buyer informs the dealer at once, and no later than one week, after detecting the failure or fault and the dealer finds the system in the state in which the system was at the moment the fault or failure was discovered.
2. The guarantee is valid if and when the buyer has filled in the warranty registration form and mailed it within two weeks of the purchase date.
3. The guarantee is not valid if and when any work has been or is carried out on the system within the guarantee period without the prior written permission of the manufacturer.
4. The guarantee claim will be processed after the defect system or the part concerned has been shown to the dealer. The buyer should also provide the warranty registration form with the stamp of the dealer and the serial number of the system as well as the original proof of purchase or cash register slip.
5. To meet the obligations under the guarantee the manufacturer is only legally entitled and obliged to deliver or repair the system or parts thereof concerned, at the discretion of the manufacturer.
6. The manufacturer is not bound by the guarantee to carry out or pay for the disassembling or installing of the system or parts thereof. Postage and handling costs are at the expense of the buyer.
7. The manufacturer is never liable for any damage to persons or goods caused by the malfunction or not functioning of the system.
8. Only Dutch law is applicable to deliveries of the system.

